

Operating  
and service  
information

**DN726**

Dual Digital Delay



**Audio engineering  
like no other  
in the world**

**DN726 V3.1 Software**

---

With no switch in place at SW6 - 9 or with the MODE switch set to MS, the unit will operate as normal, adjustment in 20 microsecond steps and the display in milliseconds. Setting the MODE switch to FIELDS will allow the unit to be adjusted in TV fields - the field delay is dependent on the selection of the RATE switch, PAL=20mS, NTSC=16.66mS. The display will show the number of fields.

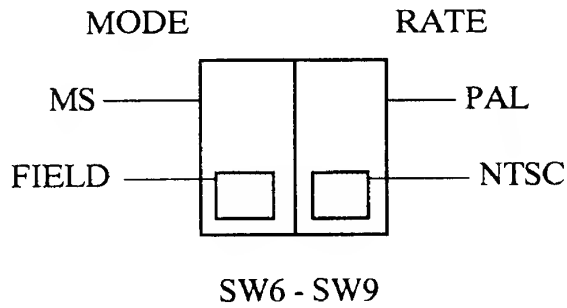

## CONTENTS

---

INTRODUCTION	4
INSTRUMENT FAMILIARISATION	9
AUDIO CONNECTIONS	11
INSTALLATION	12
SPECIFICATIONS	13
CIRCUIT DESCRIPTIONS	14
SCHEMATIC DIAGRAMS	18
VOLTAGE CHANGEOVER	19
WARRANTY	20
SERVICE REQUEST FORM	21

## **THANK YOU FOR USING THIS KLARK-TEKNIK PRODUCT**

---

To obtain maximum performance from this precision electronic product, please study these instructions carefully. Installation and operating the delay line is not complicated, but the flexibility provided by its operating features merits familiarisation with its controls and connections. This unit has been prepared to comply with the power supply requirements that exist in your location.

### **Precautions**

---

Before connecting the unit to the mains power, ensure that the operating voltage is correct for your local supply.

It is important that you observe the following instructions if another voltage setting is required.

Do not install this unit in a location subjected to excessive heat, dust or mechanical vibrations.

### **Voltage Selection and Power Connection**

---

Connection is made by means of an IEC standard power socket. The rear panel voltage label, indicates the voltage required for satisfactory operation of the unit.

Before connecting this unit to the mains supply, ensure the fuse fitted is the correct type and rating is as indicated on the rear panel, adjacent to the fuse holder.

To change the mains voltage please refer to "Voltage Change-Over" section on page 12.

\* Mains voltage change should be carried out by a qualified service technician only.

### **Safety Warning**

---

This unit is fitted with 3-pin power socket: For safety reasons the earth lead should not be disconnected. If you encounter a problem with earth-loops, use the ground-lift switch on the rear panel to isolate the signal earth from the chassis earth.

To prevent shock or fire hazard, do not expose the unit to rain or moisture. To avoid electrical shock do not remove covers. Refer servicing to qualified personnel only.

## After you have unpacked the unit

---

Save all the packing materials - they will prove valuable should it become necessary to transport or ship this product.

Please inspect this unit carefully for any signs of damage incurred during transportation. It has undergone stringent quality control inspection and tests prior to packing and left the factory in perfect condition.

If, however, the unit shows any signs of damage, notify the transportation company without delay. Only you, the consignee, may institute a claim against the carrier for damage during transportation.

If necessary, contact your supplier or as a last resort, your Klark-Teknik importing agent\*, who will fully co-operate under such circumstances.

\* See enclosed world-wide importing agents list.

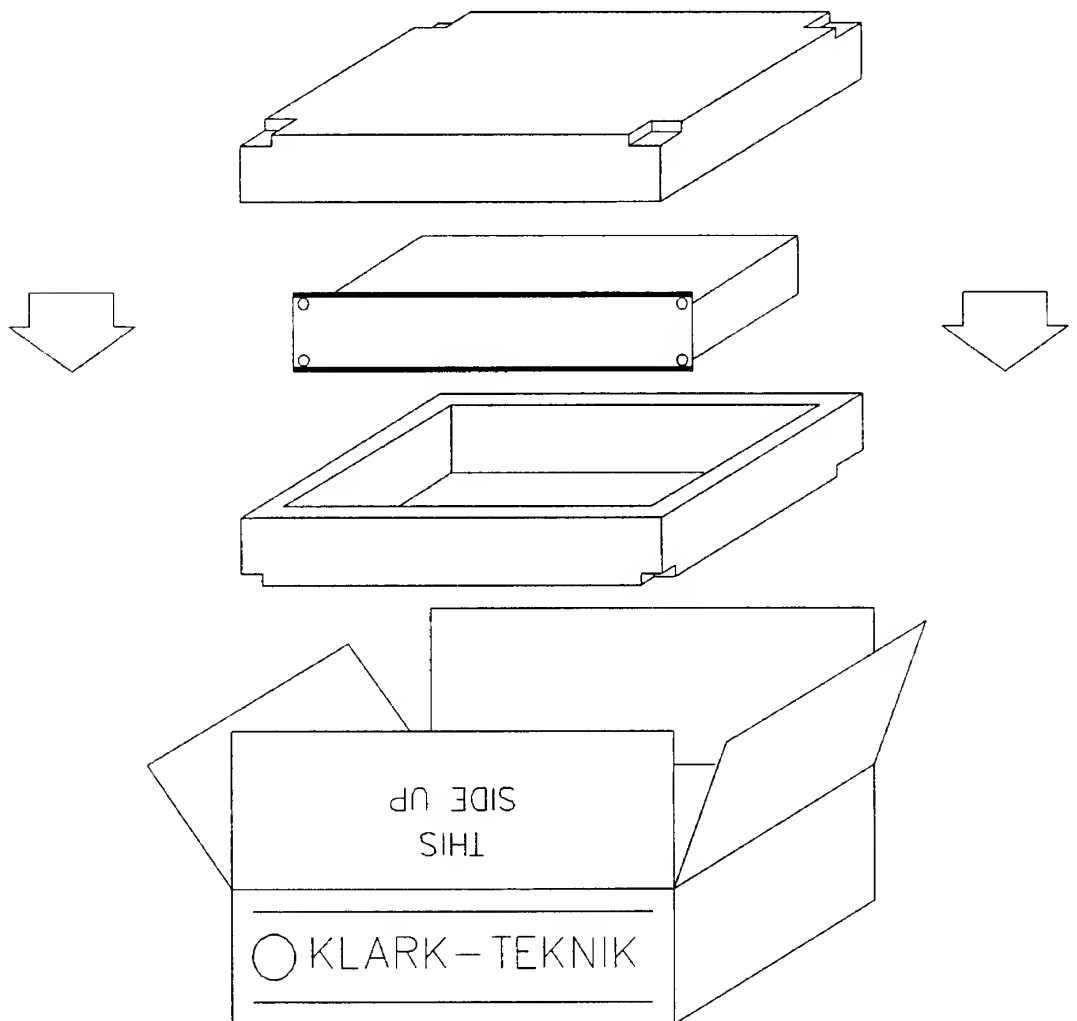

## Introduction

---

Over the past few years, the Digital Delay Line (DDL) has become one of the most widely used items of signal processing equipment to be found both in the studio and sound reinforcement installations.

Until comparatively recently the DDL tended to be regarded rather as a laboratory curiosity, with its use confined only to the very large and complex sound reinforcement systems or to the larger recording studios. Recent advances in digital technology have not only improved the electronic performance and versatility of digital delay lines, but have also brought them within the budget of the smaller studio and sound reinforcement systems, compensation of the varying signal arrival times in media/multi-path transmission systems, to creating a wide variety of completely new sounds for the recording and broadcast studio and live events. In addition, the digital delay line can also be used to alter the perceived spatial and reverberant characteristics of a room or auditorium. The wide audio bandwidth, high precision and resolution of modern delay lines also opens up new avenues of use in the field or laboratory to provide high quality delayed audio frequency signals e.g. for acoustic and electro-acoustic measurement purposes or to accurately time align loud-speaker systems and recording channels.

Many of the delay line's applications are perhaps not so immediately apparent as those of other signal processing equipment such as an equaliser for example, for many applications derive from psycho-acoustic origins as well as acoustic and physical effects.

To get the best effects from the delay line or indeed to be able to decide whether one is needed or might prove useful in a particular situation, an understanding of both the way in which the device works as well as an appreciation of some of its applications and their psycho-acoustic basis is an advantage. Because of the wide and diverse range of applications in which digital delay lines may be employed, finding the appropriate information is not always straightforward. The enclosed short form notes aim to overcome this problem by presenting a number of practical applications, together with a discussion on the underlying aspects of the physical and psycho-acoustic premise on which they are based. Essentially digital delay line applications may be divided into two distinct groups:-

- 1) Where the delay line, as its name implies, delays an audio signal in order for other signals, either acoustic or electronic, to basically "catch-up" or synchronise.
- 2) Where the delay line delays an audio signal to produce a psycho-acoustic effect or illusion.

## DN726 Digital Delay Line

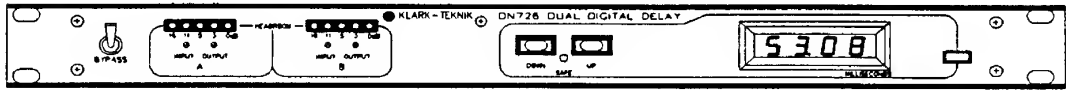

The Klark-Teknik DN726 is a stereo digital audio delay line offering over 1.3 seconds of signal delay on each channel.

In-house research and development by Klark-Teknik Engineers placed special emphasis on the design of very high quality convertors and the use of 16 bit successive approximation A/D convertor and 16 bit D/A convertor ensures optimum performance in the DN726.

The input and output filters are proprietary low-pass hybrid types, specially designed to achieve optimum noise performance, low distortion and high reliability.

A high speed CPU gives the unit increased versatility and lower component count, resulting in better reliability in a compact package.

The delay time on both channels can be changed in 20 micro-second steps from zero to 1.311 seconds. The display is auto-ranging giving the following display resolutions:-

00.00 mSec to 99.98 mSec	20 micro-second resolution
100.00 mSec to 999.9 mSec	100 micro-second resolution
1000 mSec to 1311 mSec	1 milli-second resolution

The DN726 is built to the same high electrical and mechanical standards as all Klark-Teknik equipment and is both robust and stylish. It occupies a standard one unit rack space and has an electronic balanced inputs and unbalanced outputs. Output balancing transformers are available and retrofittable.

Comprehensive diagnostic test routines for fault diagnosis are included.

### Operating Considerations

#### Audio Signal Levels

Due to the inherent limit of digital audio products it is important that special care be placed on setting the operating levels to achieve the best possible performance.

This can be achieved by the following:

- 1) Turn down to minimum the output level controls
- 2) Inject normal operating signal and turn up the input level controls as high as practical (0dB LED = 2dB below internal clipping of the unit).
- 3) Adjust the output level controls as required.

### **Displayed Delay Times**

---

Although the unit is capable of displaying the delay to an accuracy of 20 micro-seconds, the display for clarity reasons does not include a fixed delay of approximately 110 micro-seconds caused by the sampling process and necessary filter networks. Therefore the actual delay is approximately 110 micro-seconds greater than that displayed. This fixed delay varies slightly with frequency due to the filter networks.

20Hz - 5kHz	100 micro-seconds
8kHz	115 micro-seconds
13kHz	120 micro-seconds
16kHz	125 micro-seconds
18kHz	135 micro-seconds
20kHz	145 micro-seconds

### **Furthermore**

For safety and interference reasons the supply earth connection should always be used.

The audio signal ground (pin 1 XLRs) may be isolated from the chassis ground by means of the “earth lift” switch located on the rear panel. The shells of the XLRs are always connected to the chassis earth.

Do not rely on the front panel mounting as a means of chassis earthing.

Although the DN726 has been designed for minimum EMF interference it is not advisable to mount the unit near radio sensitive equipment (i.e. radio microphone receivers).

For the best possible performance in sensitive areas it is advisable that the units have transformer balanced inputs and outputs.

Make sure that the unit's voltage setting is in the correct range, incorrect setting can cause intermittent operation or excessive heating of the unit.



If normal operating conditions are adhered to, the DN726 will not require any periodic maintenance other than cosmetic removal of dust from the front panel using a dry soft cloth.

Due to the complexity of the circuitry used in the DN726 it is essential that all servicing is carried out by an authorised Klark-Teknik service technician.

Attempted repairs by non authorised service personnel will invalidate the warranty.

Diagnostic error codes on Switch-On should be reported to the nearest Klark-Teknik service point.

### **Typical Error Codes**

- 1) -EE01 Eprom
- 2) -EE02 CMOS Memory Failure (or Battery)
- 3) -EE03 Data Corruption

### **Reliability Control**

---

Even with the advanced technology incorporated in this product, each instrument is given the full backing of Klark-Teknik's "reliability control" which proves each product against a specification consistent with the highest professional standards. Only top quality components are used and every unit is bench tested and aligned before a burn-in period and a final performance test.

## Options

---

Aluminium security cover

Transformer input balancing\*

Transformer output balancing

\*Input transformer balancing is not retrofittable and has to be specified with order.

<b>Options Ordering Information</b>	<b>Part Numbers</b>
Aluminium security cover	SC71
Output balancing transformer	BU37
Input balancing transformer	BN37

### **Output Balancing Transformer Retrofit Procedure** (one transformer required per output)

- 1) Remove links on connectors ST8 and ST13
- 2) Mount transformers using screws provided
- 3) Connect transformer plugs to ST8 and ST13
- 4) Change link on ST15 to BAL position

## Instrument Familiarisation

### Front Panel Functions

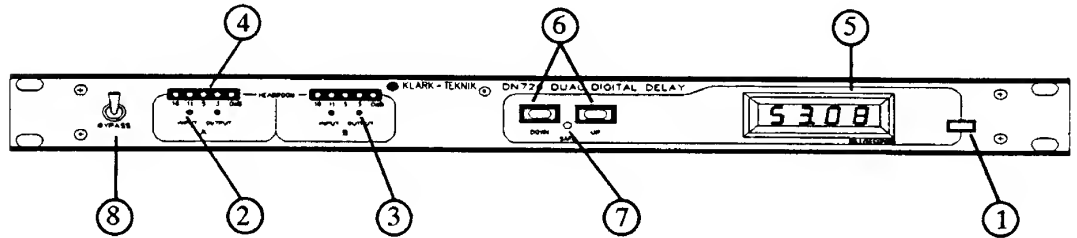

- 1) The Power Switch is a two pole type isolating both live and neutral conductors. When the power is on the display lights.
- 2) The Input Level Controls should be set so that with normal signal the 3dB LED on the headroom indicator lights up during loud passages.
- 3) The Output Level Controls are normally set at +8dBu for maximum signal level i.e. the onset of 0dB LED on the headroom indicator. The range of adjustment is from -2dBu to +18dBu for maximum level.
- 4) The Headroom Indicators show the headroom remaining in the digital section before clipping commences. The top LED (0dB) activates at 2dB below clipping.
- 5) Display shows the amount of delay (time) for both channels. The display is auto-ranging.
- 6) Delay Setting Switches. These are used to alter the delay time. The "UP" and "DOWN" switches can be used in the following manner:- Nudge - by single taps on the switch, the delay time can be incremented or decremented in 20 micro-second steps. Slow - by permanent depression of the relevant switch. Fast - by permanent depression of the relevant switch followed by the permanent depression of the other switch.
- 7) Safe Switch is an alternate action switch and is located within the front panel, so that it cannot be pressed unintentionally. Use a small screwdriver to depress it. When pressed, the delay settings are frozen and cannot be altered by the "UP" and "DOWN" switches. To return the unit to normal operation, depress the switch again.
- 8) By-pass Switch proves total signal by-pass by the use of internal relays across the XLR connectors. The unit will automatically go into signal by-pass when the power is disconnected.

## Rear Panel Functions

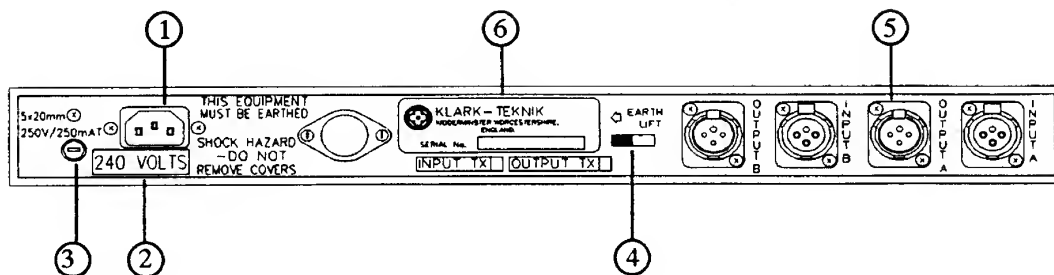

- 1) Mains is supplied via an IEC standard 3 pin connector. A compatible power cord is supplied with the unit.
- 2) Operating Voltage. This is clearly marked on an adhesive label. See "INSTALLATION" for voltage change-over instructions.
- 3) The Mains Fuse is located in a fuse holder fitted to the rear panel. Always replace with the correct type and rating of fuse, as indicated adjacent to the fuse holder.
- 4) Earth-lift Switch is situated on the rear panel, this switch disconnects the signal ground from the mains and chassis earth. This should be used if hum is attributable to earth-loops and will generally solve the problem. It is also safe, unlike the practice of disconnecting the mains earth from the power cord.
- 5) Input and Output Connections are made via complementary XLR style connectors. For wiring details see "Audio Connections".
- 6) The Serial Number of the unit should be quoted in any correspondence concerning the unit.

## Audio Connections

---

### Input

---

The input circuitry is a transformerless, electronically balanced design which achieves a symmetry of better than -50dB from 20Hz to 10kHz.

If transformer balancing of the input is required, this must be stipulated at the time of order, it is not retrofittable.

### Output

---

The standard output is unbalanced, but balancing transformers are available and may be retrospectively fitted. The output circuit is capable of driving a 600 ohm load at a level of +18dBm.

The unbalanced output XLR connections are: Pin 1 circuit ground; Pin 2 circuit ground; Pin 3 signal.

This can be changed internally to make Pin 2 the signal as follows:

- 1) Remove jumper links which short Pins 2 and 3, Pins 4 and 5 on ST8 and ST13.
- 2) Join Pins 2 and 4, Pins 3 and 5 on ST8 and ST13.

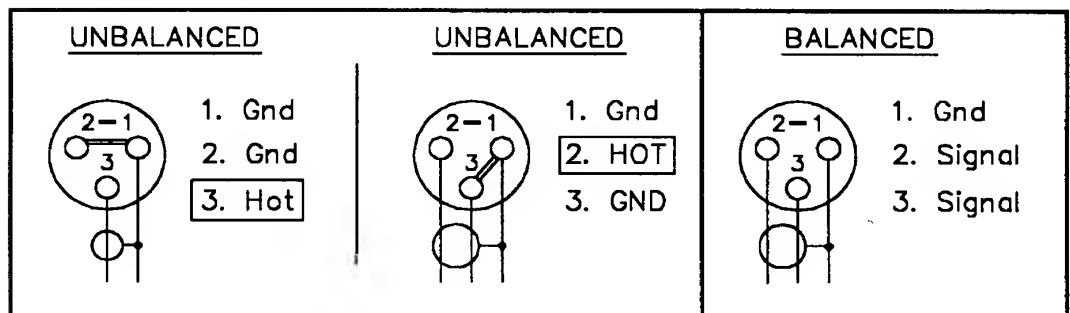

### Balanced Circuits

---

Transformer or electronically balanced connections have the benefit of “common mode rejection” which eliminates externally induced interference such as mains hum etc. Balancing is especially useful when long cable runs are used between pieces of equipment.

Transformer balanced circuits have the added advantage of being, “full floating” with the ground (earth) or screen being totally isolated from the signal. In installations where a difference in earth potential is likely to occur this isolation prevents grounding problems which can, in some cases, damage the equipment.

## **Installation**

---

### **Mounting**

---

The DN726 is designed for standard 19 inch rack mounting and is 44mm (1.75 inch) high and 300mm (11.75 inch) deep, excluding connectors. Observe the following when mounting:-

- 1) Use a well ventilated rack.
- 2) Do not mount on top of heat producing equipment.
- 3) Use fan assisted ventilation if rack exceeds 40°C

## Specifications

---

### Inputs

Type (two)	Electronically balanced
Impedance (ohm)	
Balanced	20k
Unbalanced	10k
Level	0dBu to +22dBu

### Outputs

Type (two)	Unbalanced
Min. Load Impedance	600 ohms
Source Impedance	<60 ohms
Level	+8dBm nominal for maximum level, adjustable from -2 to +18dBm

### Performance

Frequency response	+/- 1dB (20Hz-20kHz (Any level,any delay)
Total Harmonic Distortion	<0.01% @ 1kHz <0.03% @ 20Hz-20kHz (Distortion plus noise at any delay setting)
Dynamic Range	>90dB (20Hz-20kHz unweighted) (At any delay setting)

### Features

Delay Range	Adjustable from 0 to 1.311 seconds in 20 micro-second steps
Memory Retention	> 1 year (unit powered down)

### Power Requirements

Voltage	110/120/220/240V @ 50/60Hz AC
Consumption	<20VA

### Weight

Nett	2.8kg
Shipping	3.5kg

### Dimensions

Width	482mm (19 inch)
Depth	300mm (11.75 inch)
Height	44mm (1.75 inch)

### Terminations

Inputs	3 Pin XLR
Ouputs	3 Pin XLR
Power	3 Pin CEE

## **Circuit Description**

---

The system uses three printed circuit boards (PCBs).

- 1) The Main PCB (No.2681)
- 2) The Front Panel Analogue PCB (No.2653)
- 3) The Front Panel Display PCB (No.2645)

The circuits can be split into four sections:-

- 1) Power Supply
- 2) Analogue Input and Output
- 3) A/D and D/A Conversion
- 4) Digital Control Section

### **1. Power Supply (Circuit Diagrams Sheet 4)**

---

The power supply uses a toroidal mains transformer and covers the range of 95VAC at 60Hz to 250VAC at 50Hz, switched via SW3 and SW2 on the main PCB.

The three regulated DC voltages (+15, -15V and +5V) required by the DN726 are derived from three separately fused secondaries all using bridge rectifiers and linear regulators.

The DC supply can be completely isolated from the system by unplugging the connector ST2 and removing link LK1.

### **2. Analogue Input and Outputs (Circuit Diagram Sheet 1)**

---

#### **2.1 Input Section (one channel described)**

The standard unit is supplied with electronically balanced input stages. IC1a, b are configured to provide both current and voltage balancing. C8 and C9 provide RF suppression whilst in order to achieve maximum CMR (Common Mode Rejection) at high frequencies and compensate for component tolerances, C10 is selected on test. P1 adjusts low frequency CMR.

The signal from the input stage (IC1 Pin 7) goes to the input level control on the front panel analogue PCB(2653) via the cable at ST6 and returns to the buffer amplifier IC3a. This IC also provides an approximate 3dB boost at 20kHz for the SIN X/X compensation (R13,R14,C13).

The output from IC3 returns to the front panel analogue PCB to drive the LED indicator circuit (IC1). It also goes to the input of the hybrid thick film anti-aliasing filter (HB1). This is a 7 Pole elliptical low pass filter providing the bandwidth limiting required by the A/D convertor.



## **2.2 Output Section (one channel described)**

The signal from the track and hold amplifier (IC6) goes to the reconstruction filter (HB2) via the mute circuit (R39, IC12b). IC12b is a CMOS analogue switch which shorts the signal to ground during the power-on routine, preventing any “garbage” data in the memory from reaching the outputs. The reconstruction filter (HB2) is a thick film hybrid 7 pole elliptical filter that converts the digitally sampled signal into a smooth analogue signal. The output from the filter goes to the output line drive amplifier (IC7a). The gain of IC7a is controlled by the output level control on the front panel analogue PCB.

The standard output configuration is unbalanced, with the signal going via R46 to Pin 3 on the XLR connector. Output balancing transformers are available as an option, fitting instructions are on the circuit diagram.

## **2.3 Terminations**

The input circuitry is designed to operate either balanced or unbalanced. If used with an unbalanced unit it is advisable to short the unused pin to ground at the connector, especially if long cables are used. This will prevent cable capacitance affecting the high frequency performance. As both inputs (pin 2 pin 3) are identical, either one can be used as the HOT terminal. If pin 3 is used, the outputs will be in phase with the inputs at zero delay.

The outputs are unbalanced as standard and use pin 3 of the XLR's as the live signal.

The XLR configuration on both inputs and outputs can be changed by cross linking the output links LK4, 5, 9, 10 or on the outputs only by changing the configuration of the jumper links on ST8 and ST13.

## **3. A/D and D/A Conversion (Circuit Diagram Sheet 1, 5 and 6)**

---

The conversion system used is P.C.M. (Pulse Code Modulation) with 16 bit linear coding. This gives optimum performance with present technology. The A/D convertor is of the successive approximation type which enables a high sampling rate (50kHz) to be used.

The A/D and D/A conversion is accomplished using the same 16 bit DAC (IC17).

### **3.1 A/D Convertor**

During the A/D conversion, the DAC (IC17) is routed to the input section via the analogue multiplexer (IC10a,d). The A/D convertor consists of Sample and Hold amplifier IC10c,IC4), the comparator (IC8,IC13), the DAC (IC17) and the successive approximation registers (IC18,IC19).

The output from the sample and hold amplifier (IC4) is compared with the output from the DAC by the comparator. IC13 acts as a high speed low noise buffer amplifier for the comparator IC8.

In order to optimise the noise performance, it is essential that the DAC is operated around its most linear point. The bias preset P2 adjusts the offset voltages in the system and should be set for the lowest noise figure.

### **3.2 D/A Conversion**

During D/A conversion the analogue multiplexer (IC10a,d) routes the DAC output to the current to voltage convertor IC5. This voltage then goes to the input of the output sample and hold (IC12c,IC6a). The output is sampled when the signal is valid, the sequence can be seen from the timing diagram at the end of this section. The sampled output goes to the reconstruction filters via the mute circuit (described in section 2.2).

### **3.3 A/D and D/A Timing and Control (Circuit Diagrams Sheet 2)**

All timing signals for the convertors are generated from the PROM (IC57) and counter (IC47). IC58 is an 8 bit register which synchronises all the signals. The RWR signal from the microprocessor synchronises the counter with the microprocessor. Using this system eliminates all component errors and temperature drift as all the signals are locked into the master clock (6MHz).

## **4. Digital Control Section (Circuit Diagrams Sheet 3, 5 and 6)**

The entire system is controlled by the Z80 microprocessor (IC39) and its associated circuitry. The system clock is 6MHz, this is derived from the 12MHz oscillator (IC44) and divider (IC46).

The control programme is stored in the EPROM (IC40), as this cannot run at the speed required by the system, the processor copies the programme into fast RAM (IC41) as part of the start-up routine. IC45 generates the "wait states" required by the EPROM.

The front panel display is driven by IC1 on the front panel display PCB. All front panel functions are controlled by the processor via interface ICs (IC60 and IC61) on the main PCB.

The CMOS RAM (IC41) stores the delay settings and on power-down is powered by the lithium battery (BT1). This should have a minimum life of 5 years.

The power supply monitor (IC56) senses any drop out on the 5V DC supply and resets the processor. It also switches the CMOS RAM (IC41) into the battery powered standby mode.

The processor also controls the analogue data memory. The addresses, read and write signals and refresh controls are generated by the processor. The timing of these is locked into the convertor timing by the sync. pulse RWR.

**IMPORTANT WARNING**  
**THIS APPLIANCE MUST BE EARTHED**

The wires in the supplied mains lead are coloured in accordance with the following code:

Green and Yellow	Earth
Blue	Neutral
Brown	Live

As the colours of the wires in the mains lead may not correspond with the coloured markings identifying the terminals in your plug, proceed as follows:

The wire which is coloured Green and Yellow must be connected to the terminal in the plug that is marked with the letter E or by the Earth symbol  $\perp$  or coloured Green or Green and Yellow.

The wire which is coloured Blue must be connected to the terminal that is marked with the letter N or coloured Black.

The wire which is coloured Brown must be connected to the terminal which is marked with the letter L or coloured Red.

### **Voltage Selection and Power Connection**

---

Connection is made by means of an IEC standard power socket. The rear panel voltage label indicates the voltage required for satisfactory operation of the unit. Before connecting the unit to the mains power, ensure that the operating voltage is correct for your local supply. It is important that you observe the following instructions if another voltage setting is required. The unit may be set for 240v or 120v operation (50-60Hz) by means of the labelled internal slide switch. These ranges may be changed to 220v and 110v if preferred by means of the other, similar slide switch, according to the internal voltage selection label.

**Note: All internal adjustments, including voltage changes, must be carried out only by qualified service personnel.**

Before connecting this unit to the mains supply, ensure the fuse fitted is the correct and rating is as indicated on the rear panel, adjacent to the fuse holder. Should the fuse need replacing, it should be replaced only with the same type and value of fuse.

Do not install this unit in a location subjected to excessive heat, dust or mechanical vibrations.

# Warranty

This product is manufactured by Klark-Teknik and is warranted to be free from defects in components and factory workmanship under normal use and service for a period of one year from the date of purchase.

During the warranty period, Klark-Teknik will undertake to repair or at its option, replace this product at no charge to its owner when failing to perform as specified, provided the unit is returned shipping pre-paid, to the factory or authorised service facility.\*

No other warranty is expressed or implied.

This warranty shall not be applicable and be void when this product is subjected to:

- a) Repair work or alteration be persons other than those authorised by Klark-Teknik in such a manner as to injure, in the sole judgement of Klark-Teknik, the performance, stability, reliability or safety of this product.
- b) Misuse, negligence, accident, act of God, war or civil insurrection.
- c) Connection, installation, adjustment or use otherwise than in accordance with the instructions provided by Klark-Teknik.

\* See enclosed service request form.

Klark-Teknik reserves the right to alter specifications without notice. This warranty does not affect the statutory rights of the UK customer.

**COPYMASTER DO NOT REMOVE**

**NOTE!** This sheet is your Copymaster. Please duplicate on photocopier when needed.

**Service Request Form**

Please complete this form and send it to Klark-Teknik before returning the unit. Attach duplicate to the returned unit.

NAME..... TELEPHONE.....

ADDRESS.....

.....

.....

MODEL No..... SERIAL No.....

PURCHASED FROM..... DATE.....

**Please tick appropriate box**

REPLACEMENT PACKING REQUIRED     YES                       NO

- 1) Describe symptoms of malfunction.
- 2) Which channel(s) exhibit(s) the problem?
- 3) Under what conditions does the problem occur?
  - a) All the time
  - b) After a while
  - c) At high signal levels
  - d) At high temperatures
  - e) Other (please explain)

Is the fault:      Permanent                       Intermittent

- 4) What did you do to isolate the problem to this unit?
- 5) Further comments.

## **Important Note**

---

It is often useful to call your dealer or the factory explaining the nature of the problem with the unit. In many instances the problem can be solved without returning the unit to the factory. If the unit has to be returned to the factory, use the original packing only. If you do not have the original packing, we will provide a replacement.

Factory authorised service facilities are located throughout the world. Call your dealer or the factory for the location of the service facility nearest you.

**Klark Teknik PLC  
Klark Industrial Park  
Walter Nash Road  
Kidderminster  
Worcestershire  
DY11 7HJ  
England**

**Tel: (0562) 741515  
Fax: (0562) 745371**

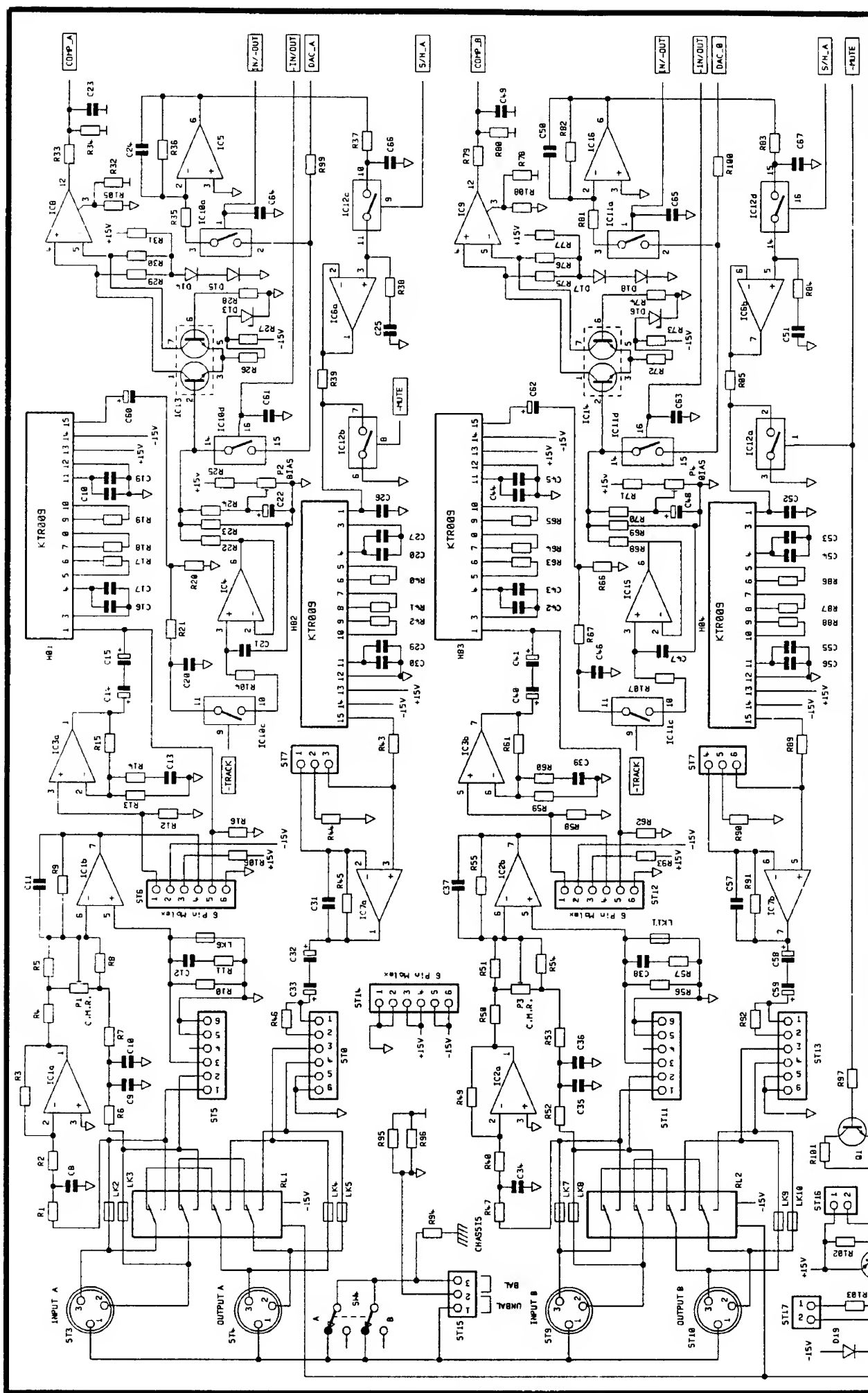



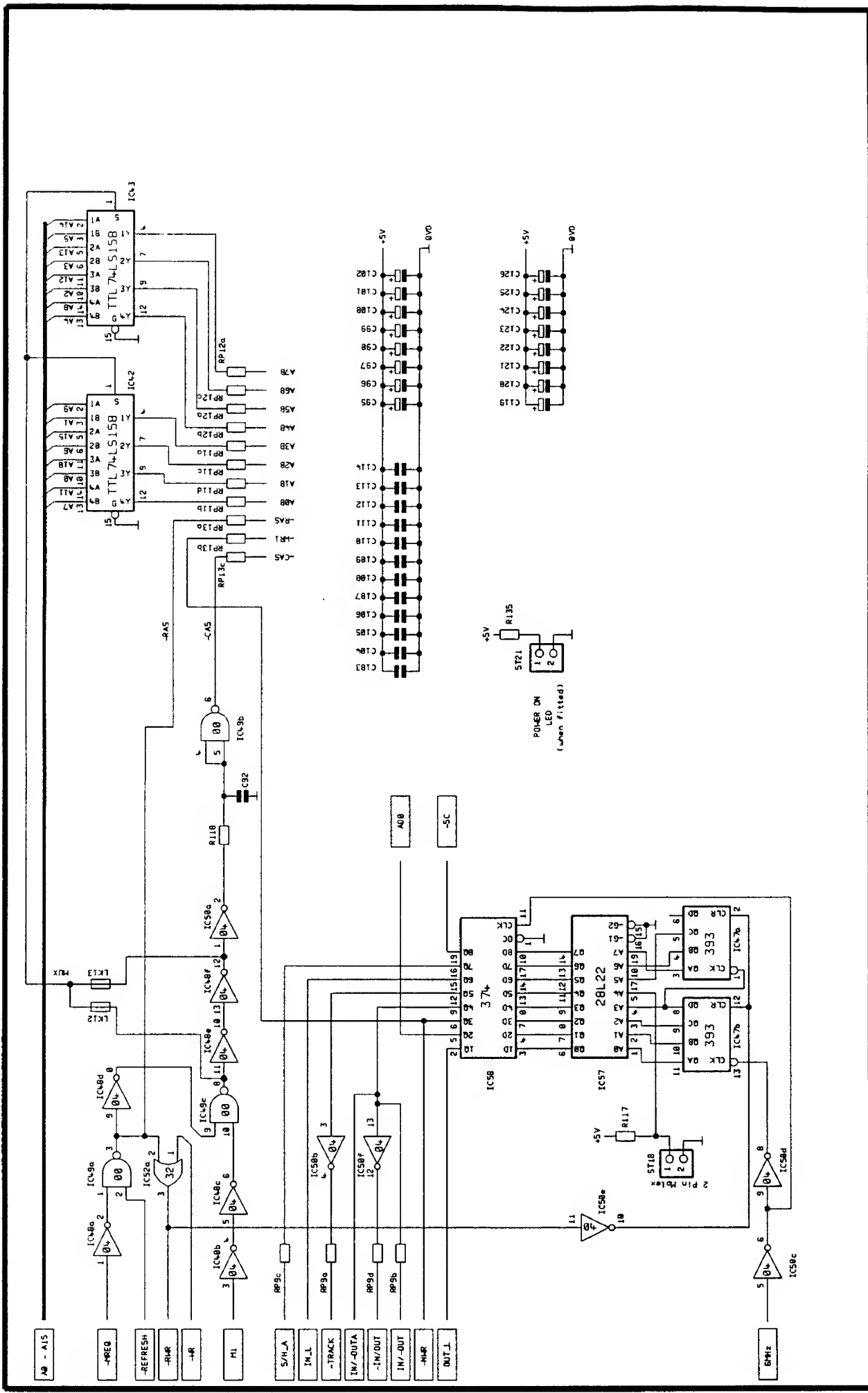



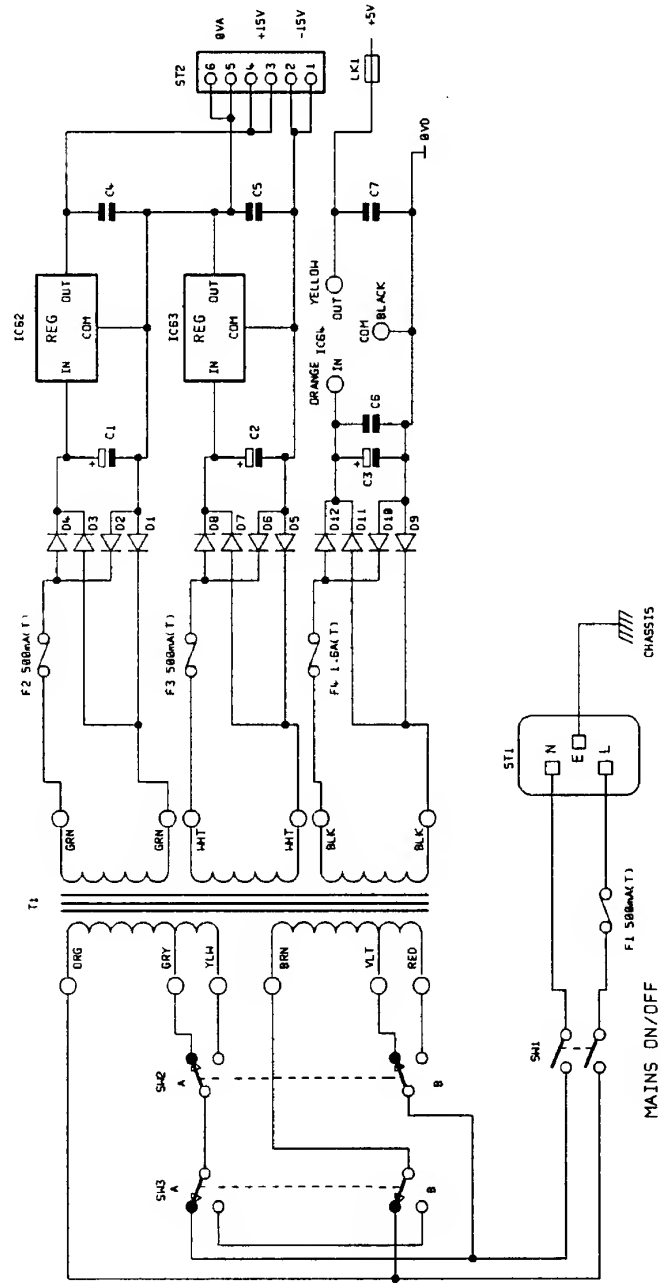

# CHANNEL A

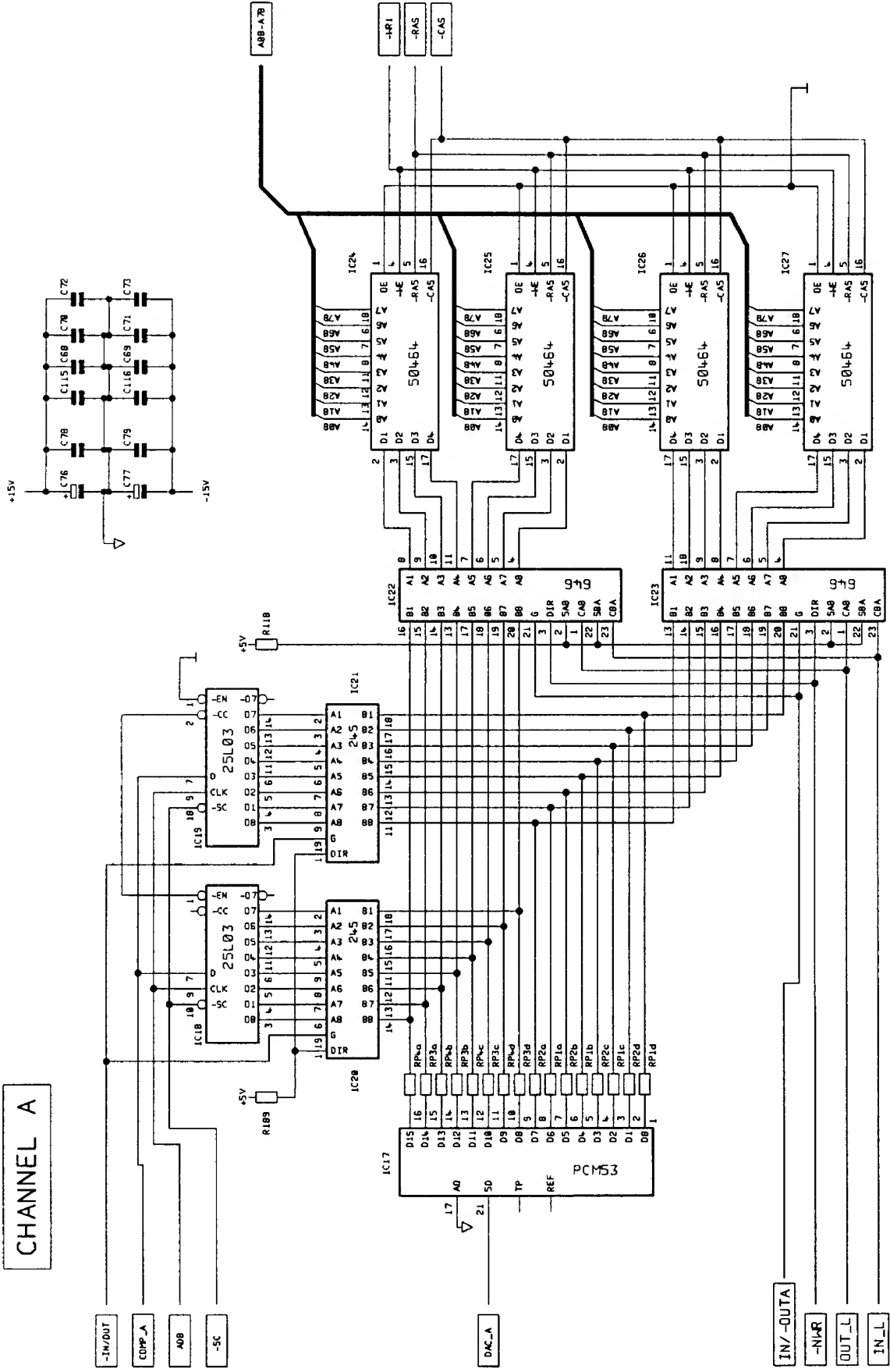

# CHANNEL B

